

SolarVu™ Installation Guide For Fronius SYMO Inverters

Introduction

SolarVu™ is an energy portal that enables remote monitoring of renewable energy generation sites over the internet. It requires the installation of a SolarVu gateway which continuously transfers data from the inverters to the remote SolarVu servers. SYMO can be ordered in 2 versions: SYMO Advanced has a DM2 (Data Manager 2) card for Modbus communication. SYMO Lite has only RS422 serial. This guide explains how to connect the SolarVu gateway to Fronius SYMO 10-24kW inverters. At least one inverter must have the DM2 card installed either by ordering a SYMO Advanced or by ordering a DM2 card separately and installing it in a SYMO Lite. Several steps are required:

- 1) Connect the SolarVu gateway to the inverters
- 2) Connect the SolarVu gateway to the building LAN for internet access
- 3) Enter the communications settings into each inverter
- 4) Access SolarVu from a browser and configure the energy portal

Site Preparation

To access SolarVu from a browser, the inverters communicate serially with a Cachelan SolarVu gateway connected to the site network as shown in fig 1. Two types of serial connection can be done:

1. The first inverter in the group must have the Fronius Data Manager 2 (DM2) P/N# 4,240,034,Z card installed. The rest of the inverters are required to have the default Comm card (RS422 card) remain unchanged.
2. All inverters have Fronius DM2 card installed.

The SolarVu gateway connects to the first inverter over RS485 using twisted pair wire, typically using Cat5e cables. Connect ethernet cable from the SolarNet IN port on the DM2 to the OUT port on the 2nd inverter. Connect another ethernet cable from the IN port on the 2nd inverter to the OUT port on the 3rd inverter and etc. Finally, plug in the link plug to the IN port on the last inverter. Make sure the 120 ohm termination switch is off on all DM2 cards. The LAN must have high speed internet service to an ISP to provide access to the internet. The SolarVu gateway RJ45 ethernet jack plugs into an RJ45 LAN jack connected to the building router using a standard Cat5e patch cable. Alternatively, SolarVu can be ordered with a 3G cellular modem for wireless internet connection. A source of 120VAC for control power needs to be connected to the SolarVu enclosure.

Site Preparation

Power Supply: Connect from a 120VAC source to the breaker (terminal L), terminal N and GND inside SolarVu enclosure as shown in fig 2.

RS485 Serial: Connect the RS485 serial Cat5e cable between the gateway terminals and Fronius SYMO DM2 card as shown in fig 3 and 4. Being careful to match the inverter type and correct wire colour to the terminals. Recommended cable type is Cat5e, 8 wire, UTP, #24 solid. Twisted pair must be used for the RS485 serial data wires. Use a tie wrap to provide strain relief for the Cat5e cable. The ground wire should be connected to an external ground to provide a path for transient protection. Over 1000 feet of wire can be used for reliable serial communications.

Ethernet: Use a standard ethernet patch cable with RJ45 plug on each end of the appropriate length to connect from the RJ45 ethernet jack on the gateway to the network ethernet at a RJ45 wall jack or router/switch. This is usually a auto IP assignment using DHCP from a small sites but a larger commercial organization may require static IP settings specified by the IT system administrator. This should be specified at time of order. Settings as shipped can be verified from the SolarVu configuration sheet included in the enclosure document pouch. Alternatively, SolarVu can be ordered with a 3G cellular modem/router installed for wireless connection. This requires installation of a customer supplied SIM card with an active telco account for service.

Fig 1 Typical connection for Acuvim II meter

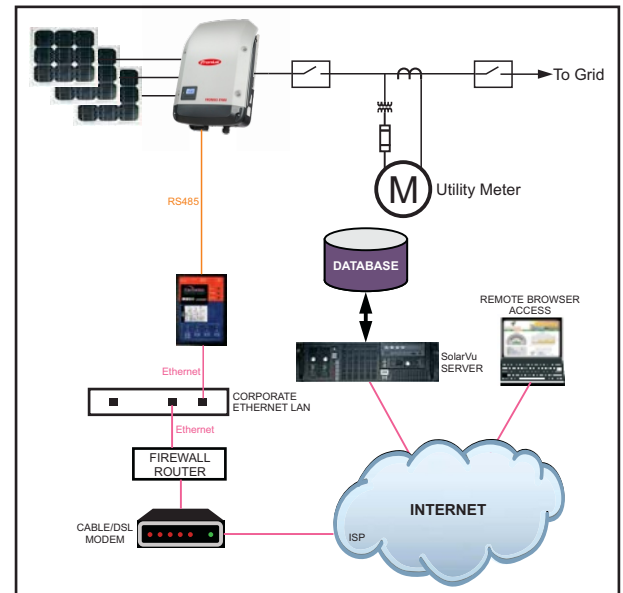

Fig 2 Typical SolarVu enclosure

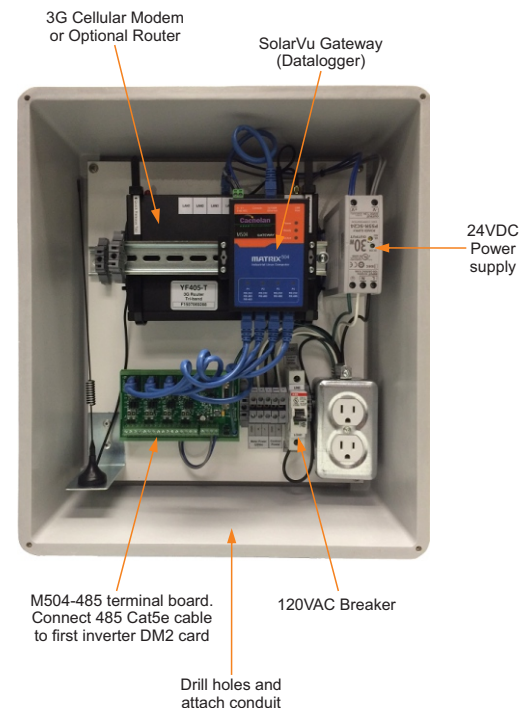
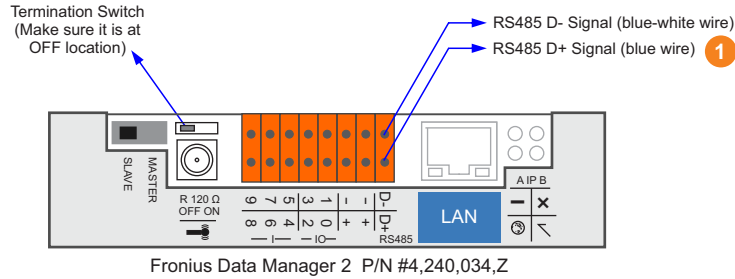

Fig 3 Fronius DM2 card layout



1 NOTE

If first inverter is **ADVANCED** and rest are **LITE**, connect RS485 terminals to SolarVu gateway and refer to Fig 4a for wiring details.

If all inverters are **ADVANCED**, connect RS485 terminals to SolarVu gateway and daisy chain the wire from first inverter to the next inverter. Refer to Fig 4b for wiring details.

Fig 4a Wiring - One Fronius **ADVANCED** with multiple **LITE** inverters

Inverter Communication Wiring - 1 **ADVANCED with multiple **LITE****

If only one inverter, connect the inverter with the DM2 installed (SYMO Advanced) to the SolarVu M504-485 Terminal Board and put both link plug at IN and OUT port. For multiple inverters, the first inverter with the DM2 installed is connected to the SolarVu M504-485 Terminal Board and the rest are connected using standard cat5e patch cables. Insert the link plugs in the first and last inverters as shown in the diagram. The DM2 terminator switch will usually be set on (one inverter only).

Make sure the termination resistor is at OFF position on the DM2 card

1 Inverter

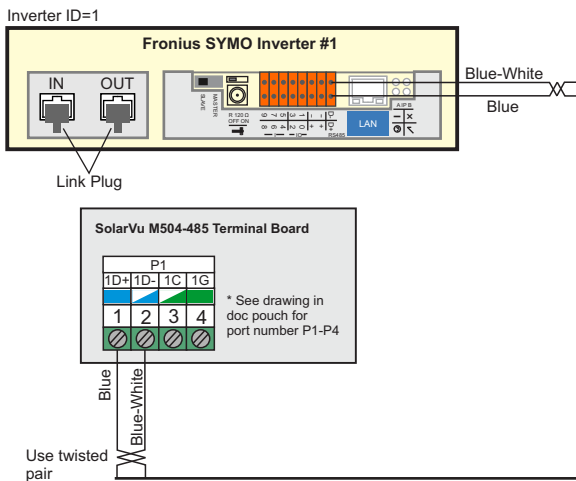

N Inverters

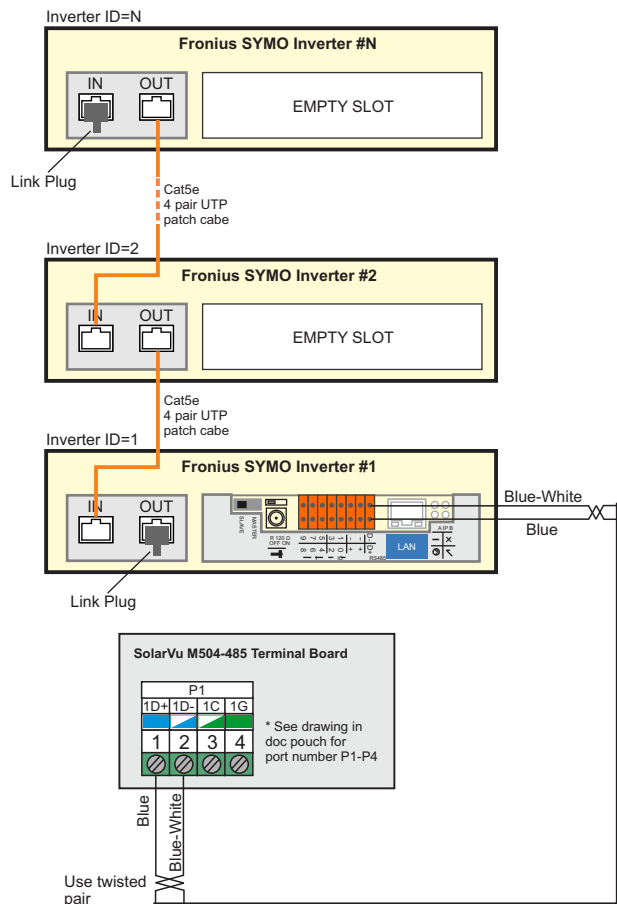

Inverter Communication Wiring - All ADVANCED

If only one inverter, connect the inverter with the DM2 installed (SYMO Advanced) to the SolarVu M504-485 Terminal Board and insert both link plug in the IN and OUT jack. For multiple inverters, the first inverter with the DM2 installed is connected to the SolarVu M504-485 Terminal Board and then daisy chain to the DM2 card on the next inverter and etc, until the last inverter is daisy chained together, all inverters are required to have both IN and OUT link plug inserted in.

1 Inverter

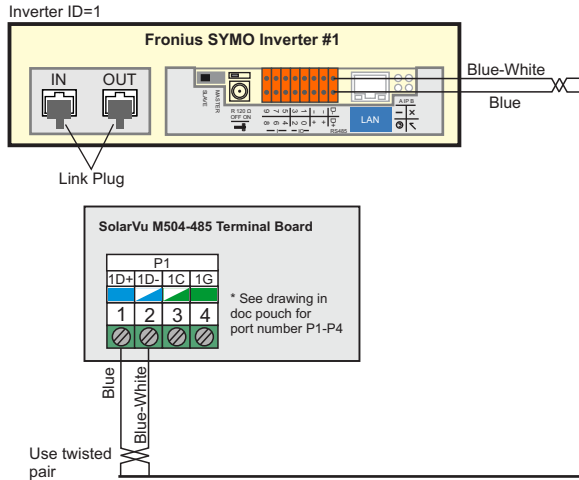

N Inverters

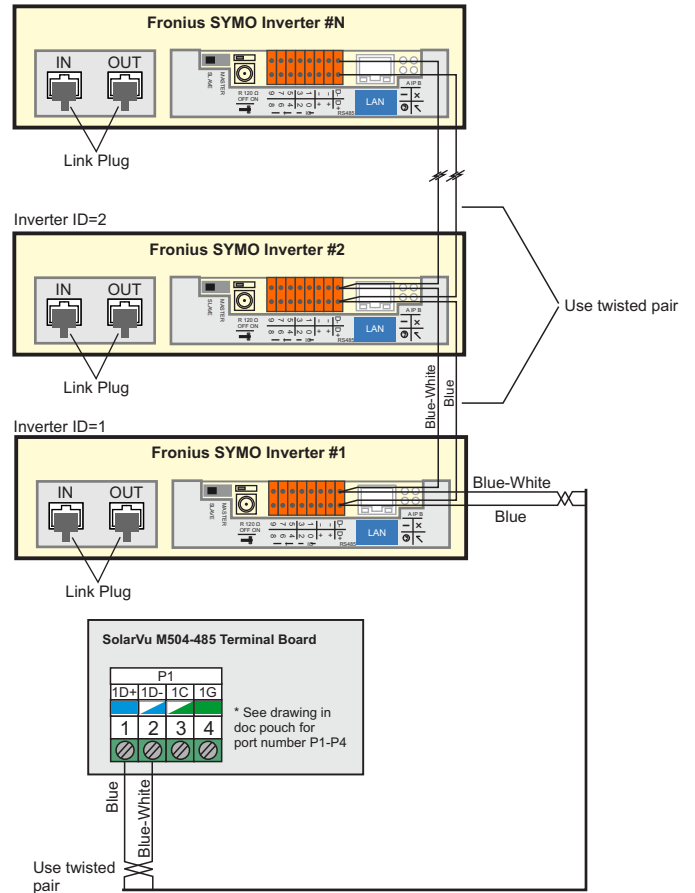

Inverter Configuration

Each SYMO inverter must be configured with a unique Inverter Number, which is also referred to as its ModBus address or ID, to match the SolarVu gateway settings for communications to work. Required inverter number settings are found in the SolarVu enclosure document pouch on the door and are normally assigned as 1,2,3... Each SYMO inverter must be powered on with a DC input to access the front panel display for entering settings. Follow the following sequence for entering the settings for each inverter individually. It may be necessary to power cycle (off then on) the inverter after making changes to ensure the inverter is using the newly assigned address ID. The default protocol setting of DATCOM can be left as is.

Fig 5 Configuring Inverter Address



On the menu level, use the 'left' or 'Right' keys to select the 'SETUP' item and press 'Enter' key to enter.



Go to 'DATCOM', press 'Enter' key to enter.

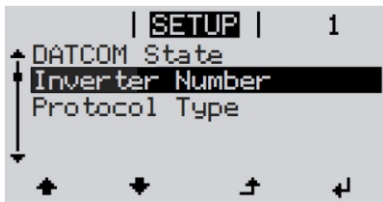

Go to 'Inverter Number', press 'Enter' key to enter.



Refer to Cachelan communication SLD for detailed inverter address assignment. Typically configure inverter address to match the inverter number, i.e. inverter #1 has address 1, inverter #2 has address 2 and etc...

To enter the address, the tenth digit will flash. Press "Up" or "Down" keys to increase or decrease the number. When done, press "Enter" key to move to the units digit.



Press "Up" or "Down" keys to increase or decrease the number. When done, press "Enter" key and both digits will flash. Then press "Enter" key again.

Network Setup

On power up, the gateway looks for a DHCP server to provide it a dynamic IP address. If a PC connected to the network can automatically connect to the internet through a browser then the network is already configured to accept the gateway. If a dedicated IP address was programmed instead, subnet mask and DNS server address are required. This needs to be entered into the gateway before shipment. Network configuration is shown on the gateway label and the Configuration Settings page in the doc pouch. Once the gateway receives its IP address it acts as a client. It will automatically try to connect to the SolarVu server and begin transferring data from the inverter to the server.

Fig 6 M504 Gateway Indicators

Blue data LED flashes when transmitting and receiving data from the inverter

504-485 Comm Board

JUMPER SETTINGS
Terminator Resistor + Biasing

B+ Bias high = ON
B- Bias low = ON
T 120R termination = ON

B+	B-	T	ON
<input type="checkbox"/>	<input type="checkbox"/>	<input type="checkbox"/>	OFF

PayCheck is normally connected to **PORT 2**. See SLD drawing in doc pouch for details

PORT1 PORT2 PORT3 PORT4

485 serial communication ports

GE828



INDICATOR STATUS		
LED	NORMAL	STATUS
Power	●	OFF-no power ON-power OK
Ready	●	ON M504 booted up and running
Link/Act	●	OFF-no ethernet connection FLASH- data traffic activity
P1	●	Serial Port 1 usually inverter Transmit=orange, Receive=green, flashing
P2	●	Serial Port 2 usually option Transmit=orange, Receive=green, flashing
P3	●	Serial Port 3 usually option Transmit=orange, Receive=green, flashing
P4	●	Serial Port 4 usually option Transmit=orange, Receive=green, flashing

TROUBLESHOOTING CHECKLIST	
IP Address	Obtain IP by DHCP or set static IP Network must be configured to same settings
Serial	Check inverter connected to correct port. Polarity of serial twisted pair wires. Serial ID entered correctly in each inverter
Inverter	Powered on. Serial ID has been set to match SLD drawing. Serial wiring correct.
Internet	Internet connection for ISP to LAN working
Support	For Cachelan technical support 905.470.8400 x224 contactus@cachelan.com

GE829

Testing the System

At this point the installation should be complete ready for testing. It is helpful to have access to a PC that is connected to the internet for viewing SolarVu screens. Using the URL supplied for the system. The gateway is preconfigured to automatically send inverter data to the SolarVu servers. To do this it must first establish an internet connection. Then it will collect data from the inverters and periodically transmit it. Verifying correct operation is described in the sections that follow. Indicator lights and actual values accessible from the SolarVu Analyzer > Inverter Status screen figure 6 are useful for determining the status of the system.

Fig 7 Use the ANALYZER > Inverter Status screen to check system status

To access the inverter status screen, enter the SolarVu URL in your browser. Click ANALYZER

Cachelan **SolarVu ENERGY PORTAL**

SITE LIVE **ANALYZER** SETUP SUPPORT HOME

Inverter Status Inverter Status HELP

Layout PowerWatch Time of last update received from SolarVu gateway Monday, November 28, 2016 4:08:33 PM (GMT -5:00)

Fronius SYMO #01 (Device ID : 1) Log Installation

Power Now 547 W	DC Input	Power 1	552 W	Voltage 1	607 V	Current 1	0.9 A	
		Power 2	228 W	Voltage 2	617 V	Current 2	0.4 A	
Lifetime Energy 6,306 kWh	AC Output	Power	547 W	Voltage	281 V	Current	2.7 A	
		Efficiency	70%	Frequency	60.0 Hz			
	Phase	Current A	0.9 A	Current B	0.8 A	Current C	1.0 A	
		Voltage A-B	281 V	Voltage B-C	283 V	Voltage C-A	284 V	
	Inverter	Fronius Symo 22.7-480				Comm	DM2 Modbus	
	Status	Normal operation						
	Fault	<input checked="" type="radio"/>	None				Error Log	Codes

Update

Listen Last Data Updated: Nov 28, 2016, Mon 4:05 PM (GMT -5:00)

Listen Last Communication: Nov 28, 2016, Mon 4:07 PM (GMT -5:00)

Measured values from the inverter

Time of last update received from SolarVu gateway

Monday, November 28, 2016 4:08:33 PM (GMT -5:00)

Nov 28, 2016, Mon 4:05 PM (GMT -5:00)

Nov 28, 2016, Mon 4:07 PM (GMT -5:00)

Status reported by inverter

Faults reported by inverter

Light is green if K135 is reading valid data from the inverter over RS485. SolarVu gateway must be connected to the internet

Light goes green if SolarVu gateway to the internet

Support

See the What is SolarVu? video at www.solarvu.net for a feature overview. Each screen has a HELP button with details for the items on that view. A printable HELP guide can be downloaded in SETUP > DOWNLOAD.

For additional technical support, send an email to contactus@cachelan.com or dial our support line in Toronto, Canada at 905.470.8400

Cachelan Technical Support
contactus@cachelan.com
 905.470.8400 x224